

NGP-6050

Crankcase Oil Capacity 8 Oz. SAE 90W
21 GPM Max. 120 PSI Max

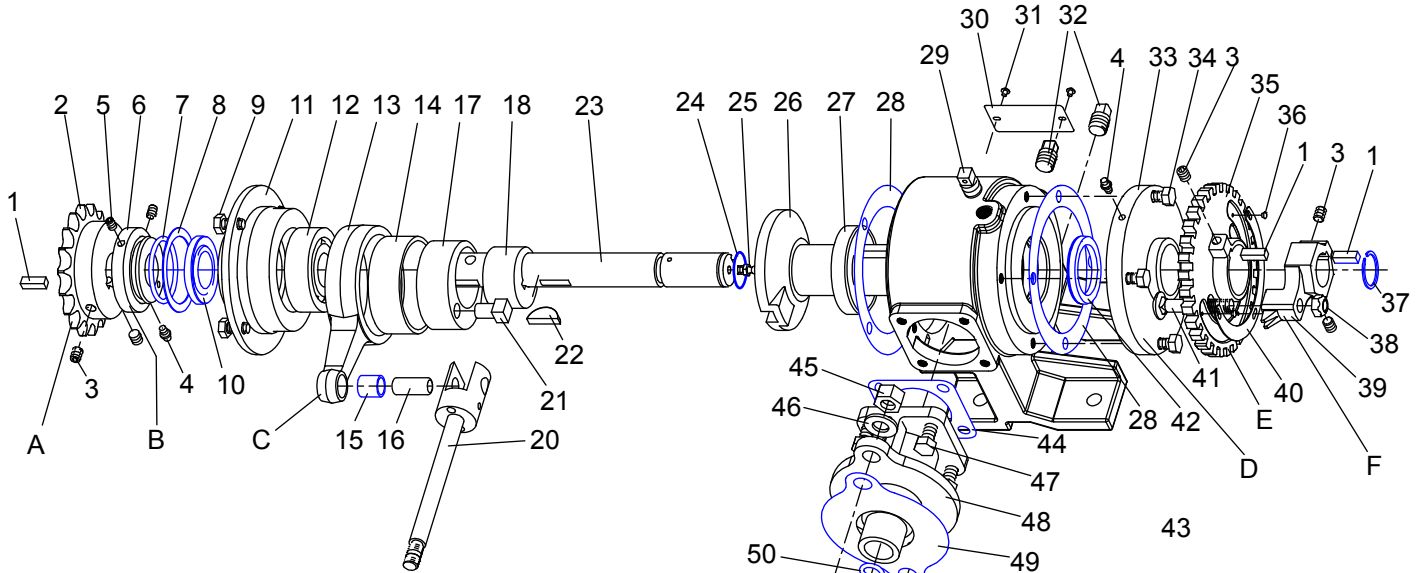

ITEM	DESCRIPTION	INCLUDES ITEM #S
A	SPROCKET	2, 3
B	SPACER	4, 5, 6, 7, 8
C	CONNECTING ROD	13, 14, 15
D	FLANGE COVER	4, 33
E	SETTING HUB	3, 35, 36, 40
F	SETTING POINTER	3, 39
G	GASKET KIT	7, 8, 10, 15, 24, 28, 37 42, 44, 49, 50, 51, 52, 53 56, 58, 59, 60, 66, 67, 68
H	OPERATORS KIT	NOT SHOWN

OPERATORS KIT:
- MANUAL
- WRENCH
- SLIDE CHART
- MOUNTING HARDWARE



Spray Advantage

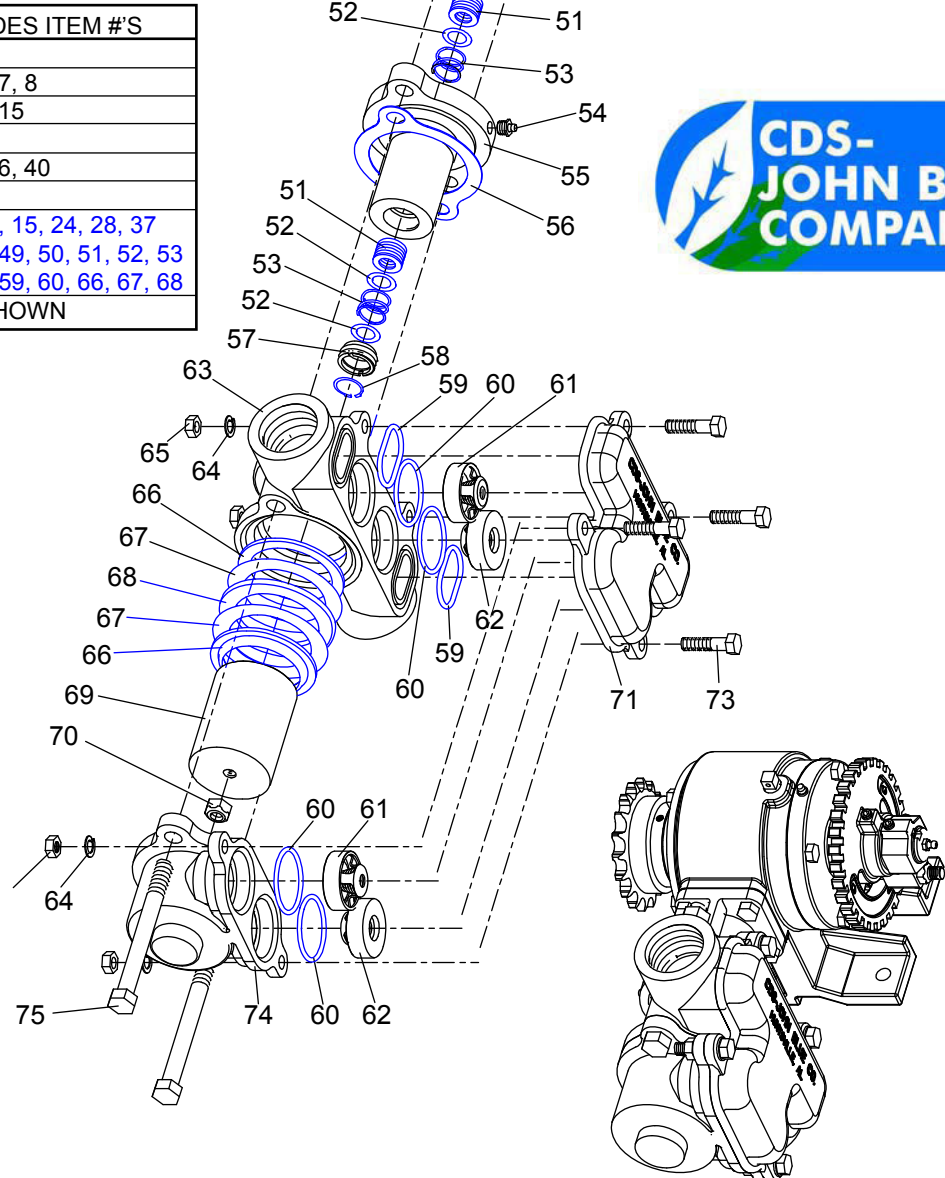

PARTS LISTING – NGP-6050

ITEM	DESCRIPTION	PART#	QTY.
1	KEY	L-1020	1
2	SPROCKET RC50-18T	112661-01	1
-K	NO SPROCKET	NOT USED	
-R	SPROCKET RC40-18T	113905-01	1
3	5/16x3/8 SET SCREW	90532	
4	GREASE FITTING	H-28	1
5	5/16x3/8 SET SCREW	90532	
6	SPROCKET SPACER	115625-01	1
7	O-RING	S-316	1
8	THRUST WASHER	115626-01	1
9	5/16x1 HEX BOLT	90637	4
10	OIL SEAL	115621-01	1
11	COVER PLATE	115723-01	1
12	BEARING	L-3019	1
13	CONNECTING ROD	L-1008-A	1
14	JOURNAL BEARING	L-928	1
15	ROD BUSHING	113588-01	1
16	ROD PIN	105895-01	1
17	ECCENTRIC- OUTER	L-1013-A	1
18	ECCENTRIC- INNER	L-1015	1
19	TRANSFER SLEEVE	NOT USED	
20	PISTON ROD ASM	115712-91	1
21	ECCENTRIC PIN	L-3004	1
22	WOODRUFF KEY	108093-01	1
23	CRANKSHAFT	115614-01	1
24	O-RING	L-1022	1
25	GREASE ZERK	115647-01	1
26	SETTING SLEEVE	115718-01	1
27	BEARING	L-1007-A	1
28	GASKET	L-1006	2
29	VENT PLUG	S-350	1
30	NAME PLATE	111958-01	1
31	DRIVE SCREW	A-3557	2
32	OIL PLUG	C-431-B	2
33	FLANGE COVER	115724-01	1
34	5/16 X 1 HEX BOLT	90637	4
35	SETTING HUB	115627-01	1
36	SCREW	A-368	2
37	SNAP RING	115791-01	1
38	3/8 SELF-LOCK NUT	A-3097	1
39	SETTING POINTER	115628-01	1
40	SETTING SCALE	115645-01	1
41	3/8x2-1/4 CARR.BOLT	115646-01	1
42	OIL SEAL	115622-01	1
43	CRANKCASE	115720-01	1
44	CROSSHEAD GASK.	115711-01	1
45	1/2 HEX NUT	92029	2
-S	STAINLESS	92030	2
46	NOT USED		
47	HEX BOLT	90637	4
48	CROSSHEAD GUIDE	115700-01	1
49	STUFF. BOX GASK.	115610-01	1
-U	FUMIGANT	104828-02	1
50	O-RING	111943-01	1
51	PACKING 'V' SET	L-1109	2
-U	@ CROSSHD GUIDE	N/A	
-U	FUMIGANT	L-1109-U	2
52	PACKING WASHER	L-1041	2
53	PACKING SPRING	L-1063	2
54	GREASEZERK	H-30	1

ITEM	DESCRIPTION	PART#	QTY
55	STUFFING BOX	115790-01	1
-S	STAINLESS	115790-01S	1
56	INBOARD CYL. GASK.	115710-01	1
-U	FUMIGANT	104826-02	1
57	STUFF. BOX INSERT	L-1031-2	1
-S	STAINLESS	NOT USED	
58	PACKING - SNAP RING	L-1042	1
59	O-RING	S-316	2
-S	STAINLESS	104824-01	2
-U	FUMIGANT	104824-01	2
60	O-RING	L-3031	4
-S	STAINLESS	114768-01	4
-U	FUMIGANT	114768-01	4
61	DISCHARGE VALVE	115707-91	2
62	SUCTION VALVE	115706-91	2
63	INBOARD CYLINDER	115701-02	1
-F	FLANGED	115701-02FLG	1
-S	STAINLESS	115701-02S	1
64	3/8 LOCK WASHER	93024	4
-S	STAINLESS	93025	4
65	3/8 HEX NUT	92024	4
66	PLUNGER- PACKING	L-1045-V	2
-B	BUNA PACKING	L-1045-A	2
67	PLUNGER- GASKET	L-1098	2
-U	FUMIGANT	114769-01	2
68	PLUNGER- WASHER	L-1044-A	1
69	PLUNGER	103290-91	1
70	PLUNGER- LOCKNUT	L-1047	1
71	VALVE COVER	115703-01	1
-S	STAINLESS	115703-01 s	1
72	NOT USED		
73	3/8 X 1-1/2 HEX BOLT	90911	4
-S	STAINLESS	90654	4
74	OUTBOARD CYL.	115702-01	1
-S	STAINLESS	115702-01 s	1
75	1/2 HEX BOLT	90704	2
-S	STAINLESS (2 BOLTS)	90693/90687	2
76	NOT USED		
77	NOT USED		
78	NOT USED		
79	SPROCKET KEY	106493-01	
A	RC50-18T SPRKT ASM	106532-01	
-K	NO SPROCKET	NOT USED	
-R	RC40-18T SPRKT ASM	113907-01	
B	SPRKT. SPACER ASM	115624-91	
C	CONN. ROD ASM	L-1008-B	
D	FLANGE COVER ASM	115725-91	
E	SET HUBASM	115629-91	
F	SET POINTER ASM	115630-91	
G	GASKET KIT	115788	
-S	GASKET KIT - SS	115788-S	
-U	GASKET KIT- FUM	115788-U	
H	OPERATORS KIT	115787	
N/S	SLIDE CHART	115698-91	
N/S	SETTING WRENCH	115631-01	

